



HP Hearing PRO



User Manual

HP Hearing PRO

Self-Fitting, Over-The-Counter,
(OTC) Hearing Aids.

Contents

Welcome	4	How to use	47
Health and Safety Information	5	Tap Touch Control	47
Indications for use	9	HP Hearing App	53
Clinical Data	10	App controls	55
What's in the box	11	How to care for your hearing aids	64
Getting to know your hearing aids	12	Replacement parts and accessories	67
Getting to know your Charge Case	13	Help and Support	68
First Time Setup	14	FAQs and troubleshooting	69
How to understand your Ear ID result	27	Regulatory and Legal Information	71
How to wear your hearing aids	29	Warnings and Cautions	73
How to manually pair	35	Technical specifications	77
How to charge your hearing aids	41		
What the LEDs mean	44		

Welcome

Thank you for purchasing HP Hearing PRO Self-Fitting Over-the-Counter (OTC) Hearing Aids. These hearing aids are designed to be worn in both ears simultaneously for ultimate hearing aid performance.

We hope you enjoy them, but before you do, please take the time to read some important information.

For safe and effective operation of the HP Hearing PRO Hearing Aids, please read the information in this User Manual and the safety, warnings, cautions and regulatory information thoroughly, before using the device.

Health and Safety Information

Warning and Cautions

Warning: If you are younger than 18, do not use this device. You should go to a doctor, preferably an ear-nose-throat doctor (an ENT), because your condition needs specialized care. Over-The-Counter hearing aids are only for users who are age 18 or older.

This OTC hearing aid is for users who are 18 and older. People who are younger than 18 with hearing loss should see a doctor, preferably an ENT, because they may need medical testing and management. Hearing loss can affect speech and learning, so professional fitting and continuing care are also important.

 **Warning:** When to See a Doctor.

If you have any of the problems listed below, please see a doctor, preferably an ear-nose-throat doctor (an ENT).

- Your ear has a birth defect or an unusual shape. Your ear was injured or deformed in an accident.
- You saw blood, pus, or fluid coming out of your ear in the past 6 months.
- Your ear feels painful or uncomfortable.
- You have a lot of ear wax, or you think something could be in your ear.
- You get really dizzy or have a feeling of spinning or swaying (called vertigo).
- Your hearing changed suddenly in the past 6 months.
- Your hearing changes: it gets worse then gets better again.
- You have worse hearing in one ear.
- You hear ringing or buzzing in only one ear.

 **Warning:** This hearing aid should not cause pain when inserting it.

Remove this device from your ear if it causes pain or discomfort when you insert it. To try again, make sure you follow the instructions. If you feel pain or discomfort, contact the manufacturer. If your pain or discomfort doesn't go away, contact your hearing healthcare professional. You can also report this to FDA as an adverse event, according to the instructions that appear later.

 **Caution:** This is not hearing protection.

You should remove this device if you experience overly loud sounds, whether short or long-lasting. If you're in a loud place, you should use the right kind of hearing protection instead of wearing this device. In general, if you would use earplugs in a loud place, you should remove this device and use earplugs.

 **Caution:** The sound output should not be uncomfortable or painful.

You should turn down the volume or remove the device if the sound output is uncomfortably loud, or painful. If you consistently need to turn the volume down, you may need to further adjust your device.

 **Caution:** You might need medical help if a piece gets stuck in your ear.

If any part of your hearing aid, like the ear tip, get stuck in your ear, and you can't easily remove it with your fingertips, get medical help as soon as you can. You should not try to use tweezers or cotton swabs because they can push the part further into your ear, injuring your eardrum or ear canal, possibly seriously.

 **Note:** If you remain concerned, consult a professional.

If you try this device and continue to struggle with or remain concerned about your hearing, you should consult with a hearing healthcare professional.

 **Note:** What you might expect when you start using a hearing aid.

A hearing aid can benefit many people with hearing loss. However, you should know it will not restore normal hearing, and you may still have some difficulty hearing over noise. Further, a hearing aid will not prevent or improve a medical condition that causes hearing loss.

People who start using hearing aids sometimes need a few weeks to get used to them. Similarly, many people find that training or counselling can help them get more out of their devices.

 **Note:** Tell FDA about injuries, malfunctions, or other adverse events.

To report a problem involving your hearing aid, you should submit information to FDA as soon as possible after the problem. FDA calls them “adverse events,” and they might include: skin irritation in your ear, injury from the device (like cuts or scratches, or burns from an overheated battery), pieces of the device getting stuck in your ear, suddenly worsening hearing loss from using the device, etc.

Instructions for reporting are available at <https://www.fda.gov/Safety/MedWatch> or call 1800-FDA-1088. You can download a form to mail to FDA.

Indications for use

The HP Hearing PRO Self-Fitting OTC Hearing Aids are intended to amplify sound for individuals 18 years of age or older with perceived mild to moderate hearing impairment. They are adjusted by the user to meet the user’s hearing needs. No pre-programming or hearing test is necessary. The device is intended for direct-to-consumer sale and use without the assistance of a hearing care professional.

Clinical Data

In a clinical study* of participants with a perceived mild to moderate hearing impairment, participants using HP Hearing PRO Hearing Aids experienced 30% improvement in speech understanding in a noisy environment with the Focus feature enabled as compared to their unaided condition. There were also significant benefits for participants in the ease of listening, sound quality and reduced annoyance from background noise. Ease of communication in quiet situations was also improved. The HP Hearing PRO Hearing Aids self-administered hearing assessment, Ear ID™, produced results consistent with their clinical audiogram. Ear ID uses the NAL-NL2 fitting formula to automatically ensure correct amplification. There were no adverse events encountered during the study.

*Based on Clinical Investigation Report: Validation of Nuheara Self-Fit Hearing Aid, Version 4, 31st January 2022 by National Acoustics Laboratories, Australia

What's in the box



User Manual
(1 Unit)



Quick Start
Guide (1 Unit)



HP Hearing PRO
Hearing Aids
(1 pair, Left & Right)

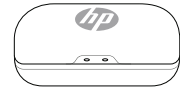

HP Hearing PRO
Charge Case
(1 Unit)

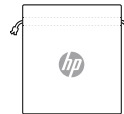

Carry Bag
(1 Unit)

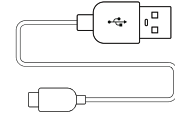

USB Charge Cable
(1 Unit)



Ear Tips
(1 Pair each of S,M,L
Foam & Silicone).
Medium Ear Tips are
pre-fitted on the
hearing aids



Cleaning Brush
(1 Unit)

Getting to know your Hearing Aids

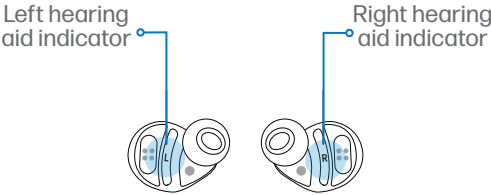

Hearing aids pre-fitted with medium (M) sized silicone Ear Tips



The highlighted blue surfaces are the Tap Touch Control Sensors

Getting to know your Charge Case

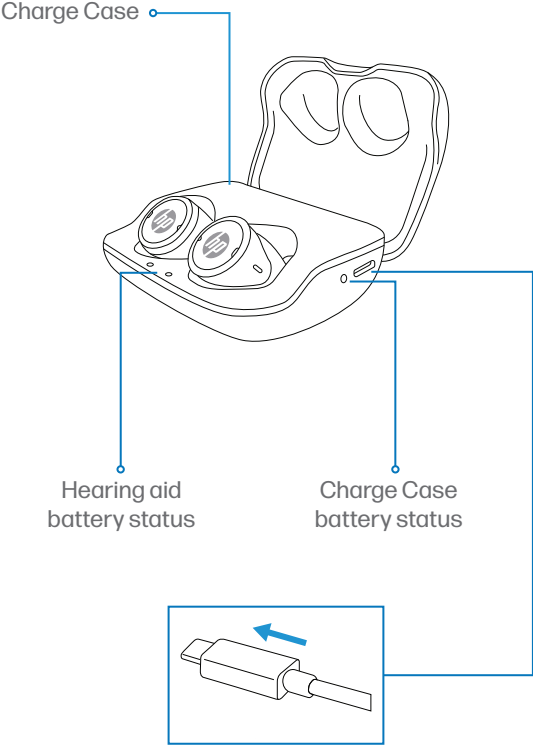

First Time Setup

Before using the hearing aids



Step 1/12

Download the HP Hearing App from the App Store on your iPhone® or from the Google Play store for an Android phone.



Step 2/12

Launch the HP Hearing App and follow the instructions for setup.

The HP Hearing App will guide you through pairing your hearing aids to your iPhone or Android phone. iOS 11 or higher is required to use the hearing aids with an iPhone, and Android 10 or higher for Android phones.

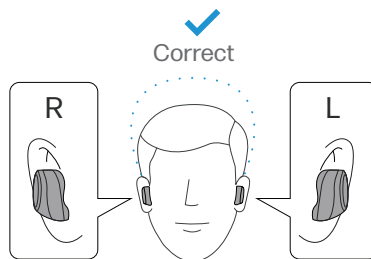

You need to wear both hearing aids at the same time.

Step 3/12

Ensure the hearing aid with the L indicator is in the Left ear and the hearing aid with the R indicator is in the Right ear. You are ready to commence personalizing your hearing aid.

HP Hearing PRO Hearing Aids are designed to be worn in both ears simultaneously for ultimate hearing aid performance.

Do not insert the hearing aids without Ear Tips being fitted.

Step 4/12

To pair your hearing aids, apply light pressure to the Tap Sensors on both hearing aids for 5 seconds - until you hear "Pairing".

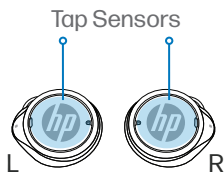

Hold Tap Sensors for 5 seconds until you hear "Pairing"

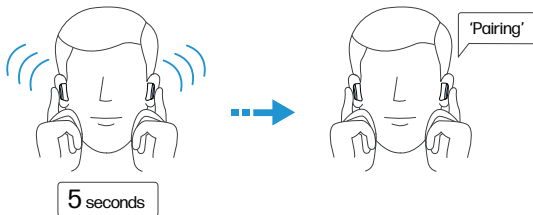

iOS phones

Accept the pairing by tapping "Pair" in the app to pair both the left and right hearing aids for iPhone.

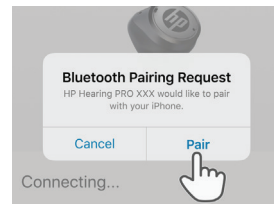

Android phones

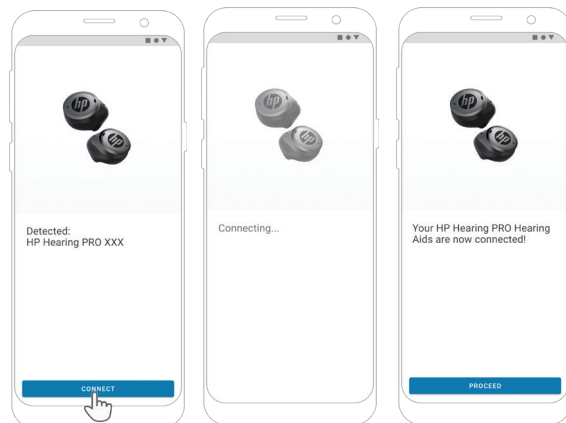

For Android phones, once the HP Hearing PRO XXX (*XXX represents your hearing aid's unique pairing number*) hearing aids have been detected, tap "connect".

i **Note:** Android instruction may vary depending on your device. Follow your phone's instruction to pair Bluetooth devices.

Step 5/12

Before the hearing aids are paired, the **HP Hearing App** will ask you to accept HP Hearing PRO Terms & Conditions as well as the Privacy Policy. You will be prompted to make it official by registering your product to receive important updates and support.

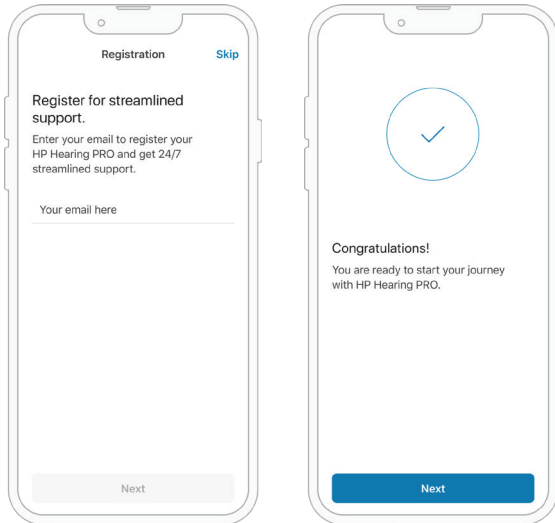

Step 6/12

You will be prompted to set up your Ear ID. It is important to complete this step, as it is used to program the hearing aids to your personal hearing profile.

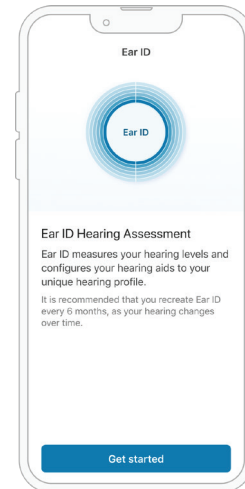

Step 7/12

Your Ear ID evaluation process may take up to 10 minutes to complete. Please be patient during this process and follow all instructions. This process needs to be completed in a quiet room.

Step 8/12

The HP Hearing App will guide you to Ear Tip Check to detect if your Ear Tips fit you well. If your Ear Tips do not fit you as they should, the app will take you to the screen with information to guide you in selecting the best size Ear Tips for optimal hearing performance before you create your Ear ID profile. The hearing aids come with the medium sized, silicone Ear Tips, pre-mounted. Follow the steps to ensure the hearing aids have a good seal and snug fit by selecting the best Ear Tip size for you.

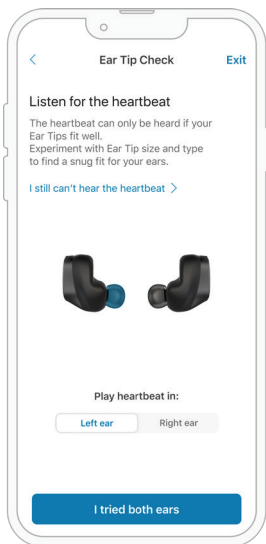
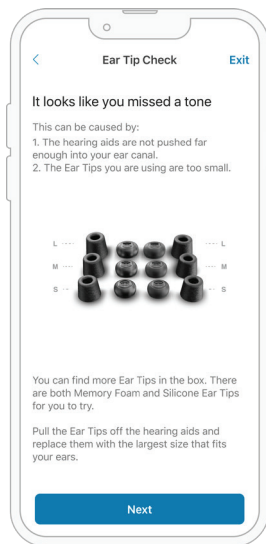

Do not insert the hearing aids without Ear Tips being fitted.

The Ear Tips included with the HP Hearing PRO Hearing Aids are designed to properly fit most ear canals and provide reasonable assurance of safety that the hearing aids cannot be inserted too deeply into the ear canal. The Ear Tips combined with the hearing aid are designed to provide a setback from the eardrum (also known as the tympanic membrane) of at least 10mm for most ear canals. The setback is from the innermost component of the device to the eardrum and this setback ensures for most ear canals the risk of injury to the eardrum is minimized.

⚠ Caution: DO NOT force the hearing aid into your ear canal to the point where it is painful or uncomfortable as this may cause damage to your ear canal.

i Note: If you miss a tone then this may indicate that you require a better fitting Ear Tip. A screen will appear to prompt you to try another. Another screen allows you to test new Ear Tips in both ears, using a heartbeat sound to verify the Ear Tip seal in each ear.

Step 9/12

Tones are played in the left and right ear separately. The assessment identifies the quietest tone you can hear in each frequency. Do not be concerned if you cannot hear all tones. This is a normal part of the test process. You may experience some gaps in hearing tones which is also normal.

i **Note:** If you open a different App or receive a phone call, notifications or are interrupted during the hearing assessment it may be necessary to start again.

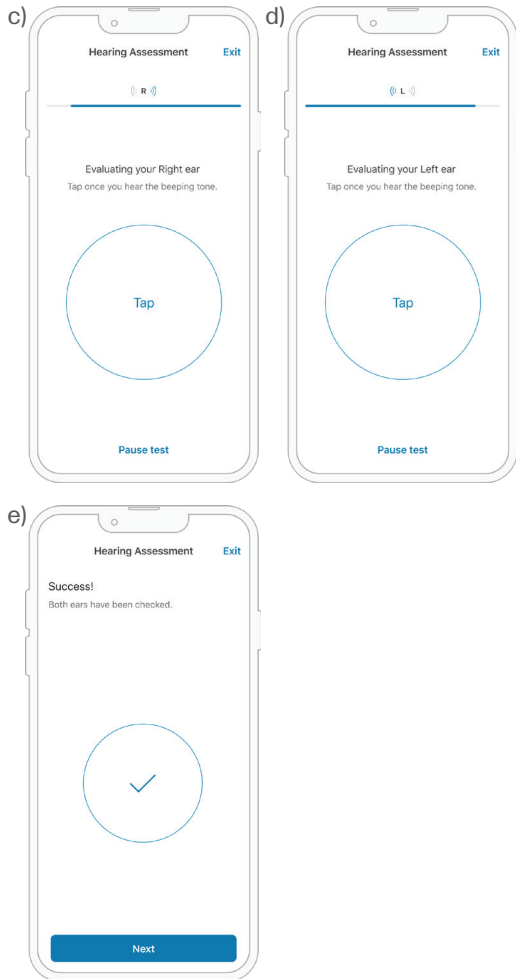
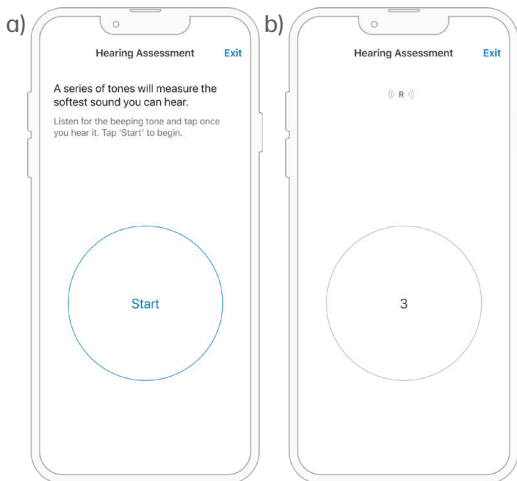

Step 10/12

You will then be asked a series of questions before your Ear ID profile can be created.

Note: Your Ear ID is presented on completion of your profile and amplification is applied to the left and right hearing aid.

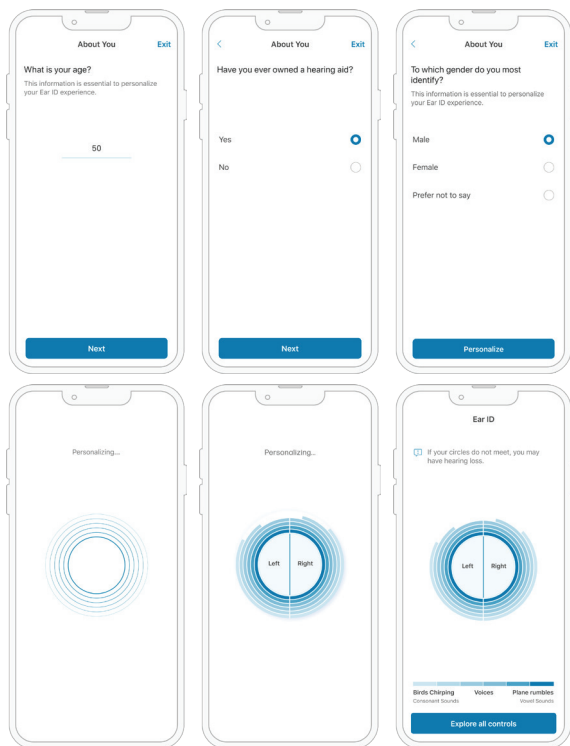

Step 11/12

You will be guided to familiarize yourself with the HP Hearing PRO controls, which explains how to make and receive phone calls using your hearing aids, control the World Volume around you, and Focus on speech in noisy environments.

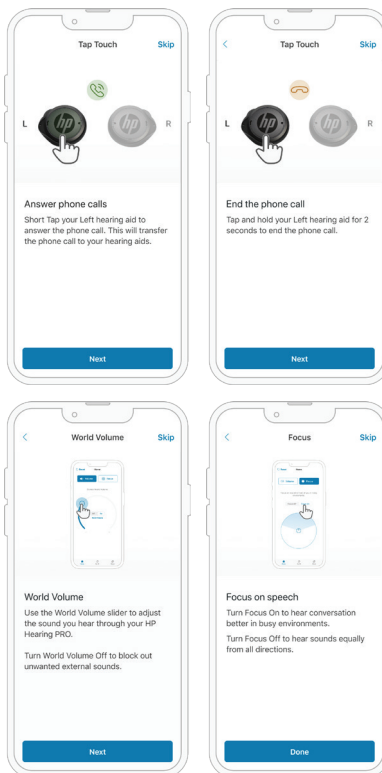

Step 12/12

Congratulations, your hearing aids have been personalized and are ready to be used.

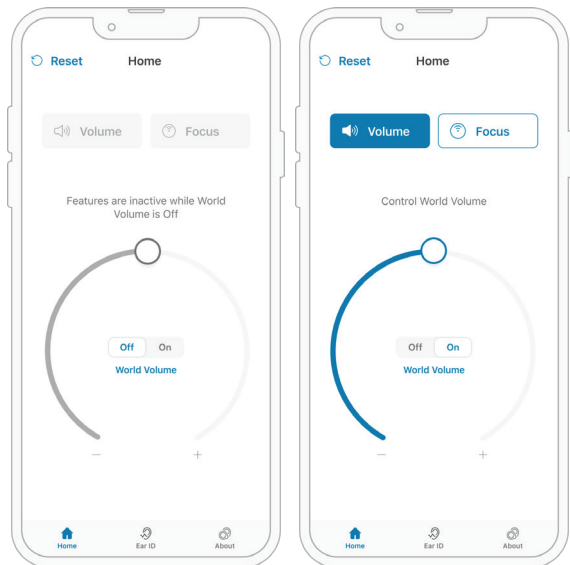

How to understand your Ear ID result

Ear ID assesses your ability to hear soft tones. Your HP Hearing PRO will be programmed based the softest tone you could hear.



These circles indicate different tone levels heard in the Left and Right ear.

This chart explains how the color of the circles relate to different tones.



If your circles do not meet, you may have hearing loss.

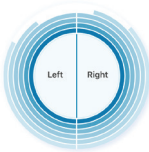

Some high tones have been missed. You may struggle to hear sounds like birds chirping.

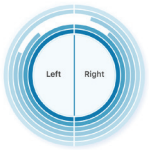

Some mid tones have been missed. You may struggle to hear some conversations.

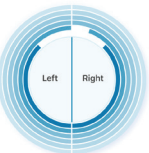

Some low tones have been missed. You may struggle to hear sounds like plane rumbles.

How to wear your hearing aids

The Ear Tips included with the HP Hearing PRO Hearing Aids are designed to properly fit most ear canals and provide reasonable assurance of safety that the hearing aids cannot be inserted too deep into the ear canal providing an expected distance (setback) from the eardrum (tympanic membrane): 10mm setback from the innermost component of the device to the eardrum (tympanic membrane) for most ear canals to minimize the risk of injury to the eardrum (tympanic membrane). Insert the hearing aids into your ears with the Ear Tip at the bottom when inserting, gently push and twist them as indicated until you have a snug, yet comfortable fit.



Caution: DO NOT force the hearing aid into your ear canal to a point where it is painful or uncomfortable as this may cause damage to your ear canal.

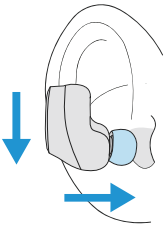

1. Insert hearing aid into the ear canal in the vertical position with the Ear Tip at the bottom when inserting.

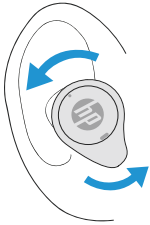

2. Twist the hearing aid slightly towards the back of the head to achieve "lock" and complete seal.

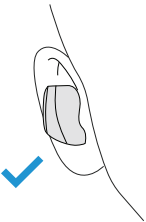

3. The hearing aid should remain securely in the ear canal and feel snug in your ear.

If you have chosen to use the Memory Foam Ear Tips, be sure to squeeze down on the foam with your fingers before inserting the hearing aids into your ears.

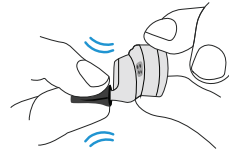

1. Squeeze down on the memory foam Ear Tip with your fingers to compress the foam.

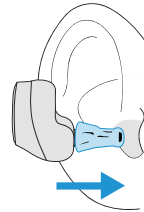

2. Insert hearing aid into the ear canal in the vertical position with the Ear Tip at the bottom when inserting. Hold in place until the Memory Foam expands.

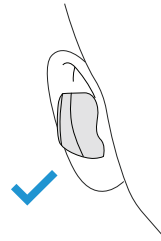

3. The hearing aid should remain securely in the ear canal and feel snug in your ear.

How to change your Ear Tips

It is important to wear the hearing aids correctly with the correct Ear Tips size for your ears to ensure the optimal audio and hearing experience. The medium Ear Tips will fit most people; however, your ear may need a different Ear Tip size. If you cannot get a snug and comfortable fit, it is recommended to try a different Ear Tip size.

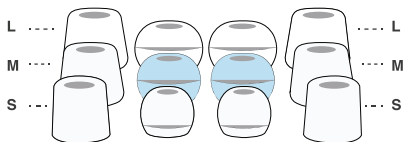

The hearing aids come with two types of Ear Tips: Silicone and Memory Foam. Each type is supplied in small, medium, and large sizes. Choose the type that provides you with the best combination of snugness for fit and comfort. Only use the HP Hearing PRO supplied Ear Tips.

To change your Ear Tips to Memory Foam tips, firmly pull the current Ear Tip off the hearing aid and replace it with a different size.

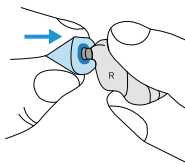

1. Align the Memory Foam Ear Tip and sound port of the hearing aid.

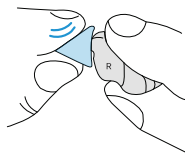

2. Press the Memory Ear Tip on to the sound port.

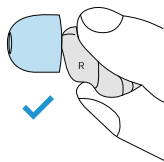

3. Memory Foam Ear Tip should be fully mounted on the sound port.

To change your Silicone Ear Tips, firmly pull the current Ear Tip off the hearing aid and replace it with a different size.

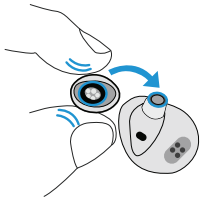

1. Align the oval shapes on the Ear Tip and sound port of the hearing aid.

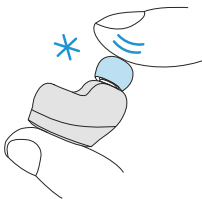

2. Press the Silicone Ear Tip on to the sound port.

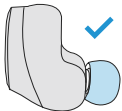

3. Ensure the Silicone Ear Tip is fully attached.

Selecting Ear Tips that are too small may lead to listening fatigue, cause you to miss sound awareness, or cause the hearing aids to fall out of your ear. Selecting Ear Tips that are too big may lead to discomfort and ear pain. Ear Tips that are not properly mounted on the hearing aid may come loose in the ear.

How to Manually Pair

Follow the steps below to manually pair your hearing aids.

Step 1/3

Remove the hearing aids from the Charge Case to power them on.

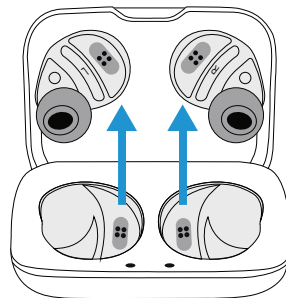

Take both hearing aids out of the case
You need to wear both at the same time.

Step 2/3

Place both hearing aids into your ears.

The highlighted blue surfaces in this diagram are the Tap Touch Control sensors. To activate pairing mode, apply light pressure to both Tap Touch Control sensors for about 5 seconds and wait until you hear "Pairing".

This will allow your phone to discover the hearing aids in Bluetooth settings and in the HP Hearing App.



Hold both Tap Touch Controls until you hear "Pairing".

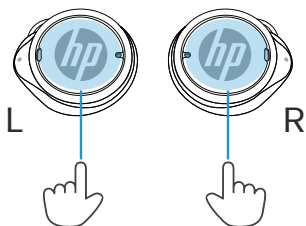

Step 3/3

iOS Manual Pairing

To activate pairing manually you need to open the Bluetooth Settings and check if the Bluetooth is turned on, then select HP Hearing PRO from the list of available devices to connect. Return to the HP Hearing App to continue to use your hearing aids.

Note: HP Hearing PRO Hearing Aids have a unique three letter/number identifying code that will appear - HP Hearing PRO xxx

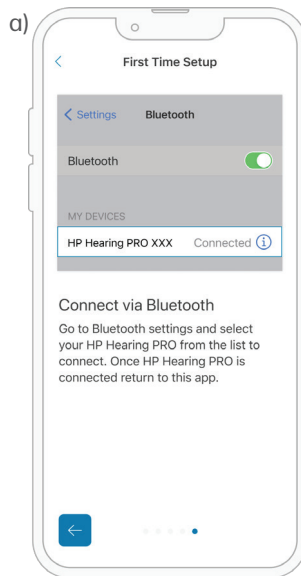

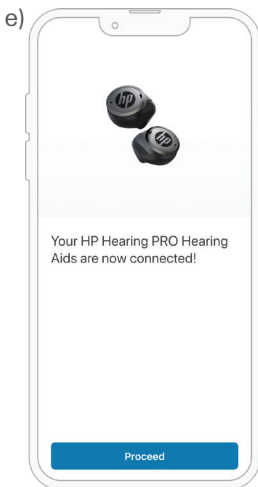
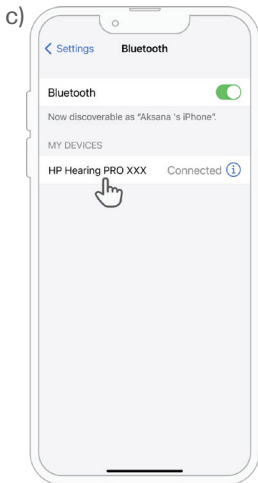
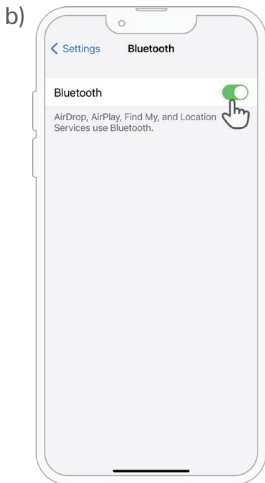

Android Manual Pairing

For Android 10 or higher phones, after lightly pressing Tap Touch Control sensors for about 5 seconds and hear “Pairing”, the phone will connect to the hearing aids.

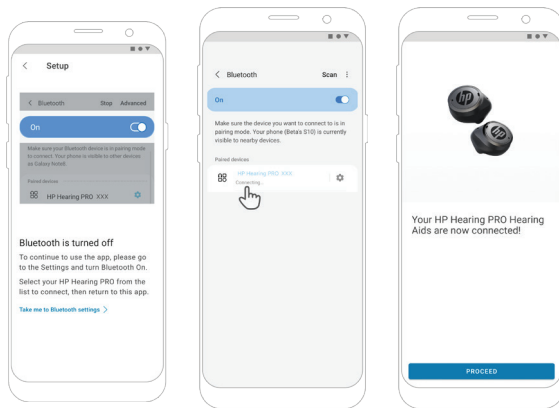

If Bluetooth is turned off on your phone, you may need to turn it on and select the hearing aid from your list of Bluetooth devices previously connected to your phone.

 **Note:**

- Up to 4 devices can be paired with the hearing aids and stored in the hearing aid's memory, however you can only connect the hearing aids to one device at a time.
- In order to change which device you are connected to, activate Pairing Mode by ightly pressing both Tap Touch Control Sensors for 5 seconds until "Pairing" is heard. On your other device, now navigate to the Bluetooth settings and search for HP Hearing PRO XXX and connect to it.
- The Bluetooth range of the hearing aids is approximately 32 feet (10 meters) when there is no interference.

How to charge your hearing aids

The HP Hearing PRO Hearing Aids last up to 8 hours on a single charge* and offers up to a total of 24 hours of on-the-go battery life when used with the Charge Case*.

 **Note:** The Hearing aid battery life may be reduced when using steaming media and hearing processing simultaneously. E.g., Listening to music while also using World Volume to amplify your environment.

The hearing aids provide audible notification to the user when the battery is getting too low.

* tested to internal Situation Awareness Setup protocol using Bluetooth connected, World On - Setting (0dB, 106), Focus Off, Wind Reduction Algorithm On.

Charge the hearing aids

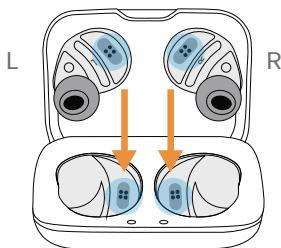

Ensure the left hearing aid is charged in the left socket and the right hearing aid is charged in the right socket.

Place the hearing aids in the Charge Case and close the lid. It takes up to 3 hours to fully recharge the hearing aids when they are completely out of battery. When charging the hearing aids and placing them in the Charge Case, align the gold contacts on the hearing aid with the gold contacts in the Charge Case. Ensure the Charge Case door is closed during charging.

Charge the Charge Case via USB

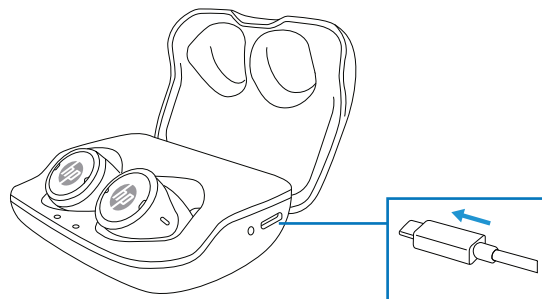

Plug the supplied USB Charging Cable into a USB power outlet or AC Plug Pack (not included) and then connect the cable to the USB port on the Charge Case. It takes up to 3 hours to fully charge the hearing aids and the Charge Case when using AC Plug Pack model CUI # SWM6-5-NH-I38 (recommended, not included). The AC Plug pack output voltage is 5V with an output current of 1.2A.

i **Note:** The Charge Case internal battery needs to be charged to charge the hearing aids. The Charge Case uses USB voltage of 5V. Do not charge the hearing aids using a power outlet with a higher voltage.

⚠ **Warning:** Only use the Charge Case and USB Charging Cable supplied with the hearing aids.

What the LEDs mean

When unplugged

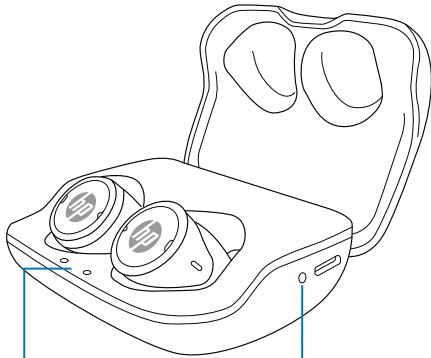

- Charge Case holds more than one full charge for the hearing aids.
- Charge Case holds less than one full charge for the hearing aids.
- Hearing aids are fully charged.
- Hearing aids are charging or low charge.

When plugged in

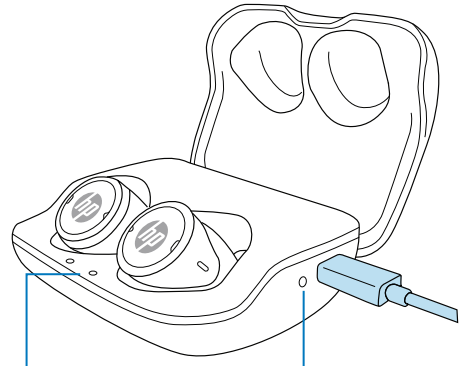

- Charge Case is fully charged.
- Charge Case is charging.
- Hearing aids are fully charged.
- Hearing aids are charging or low charge.

Hearing Aid Battery Status

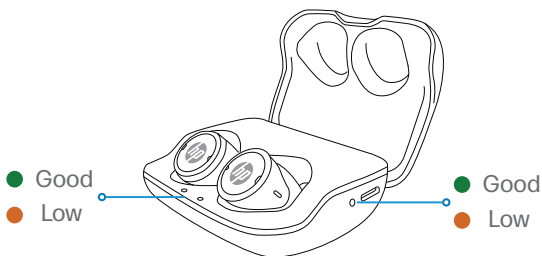

The Charge Case will supply power to the hearing aids to recharge the internal batteries. When the hearing aids are placed in the Charge Case, the LEDs on the Charge Case will light up solid green for fully charged or amber if the hearing aid battery requires charging. The hearing aid battery status will appear when you open the Charge Case lid.

Charge Case Battery Status

When the lid of the Charge Case is opened, the LED on the side of the Charge Case will light amber or green to indicate the battery status of the Charge Case.

Note: When the hearing aids are in the Charge Case the lights will turn on when the lid is opened or closed. The lights will then turn off after a few seconds to save the battery. The hearing aids must be in the Charge Case for the front lights to activate.

How to use

HP Hearing PRO Hearing Aids are sophisticated medical devices which:

- Stream music and audio with high fidelity from Bluetooth connected devices.
- Provide environmental sound amplification or reduction (Active Noise Cancellation).
- Focus sound amplification to the front for better communication.
- Adapt to the user's individual hearing profile using data from the Ear ID feature.

HP Hearing PRO Hearing Aids can be operated by Tap Touch Control or via the HP Hearing App.

Tap Touch Control

Use the **Tap Touch Control** feature in the HP Hearing App to pair your device and control phone calls.

Find Tap Touch Controls in the App.

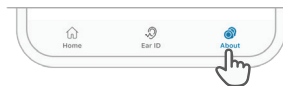

Tap **About** in the **Menu Bar** at the bottom of the HP Hearing App screen.

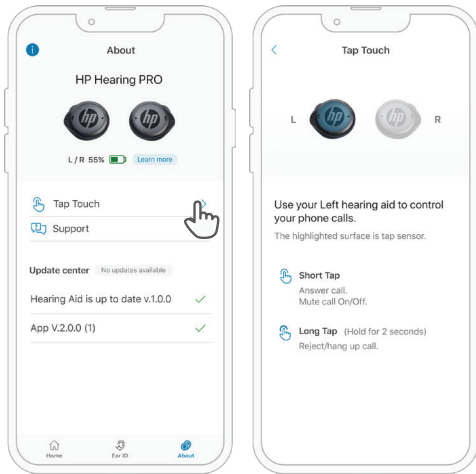

Select **Tap Touch** to learn how to use Tap Touch Control on your Left hearing aid to answer the phone on your device.

Tap Touch Control Phone Settings

The Tap Touch Control feature includes standard non-configurable settings for managing phone calls. These include:

- Short Tap to answer calls, mute calls On/Off.
- Long Tap (Hold for 2 sec) to hang up calls.

Hands Free Phone Calls

Use Tap Control to direct phone calls to your hearing aids and follow conversations without holding your phone.

Use your **left** hearing aid to control your phone calls.

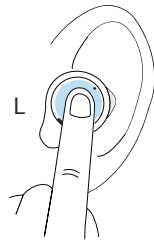

Short Tap
Answer call
Mute call On/Off



Long Tap
(Hold for 2 secs)
Hang up call

Ear ID

Tap **Ear ID** in the **Menu Bar** at the bottom of the HP Hearing App screen.



Ensure Ear ID is on in order to calibrate the HP Hearing PRO Hearing Aids to your personal hearing profile.

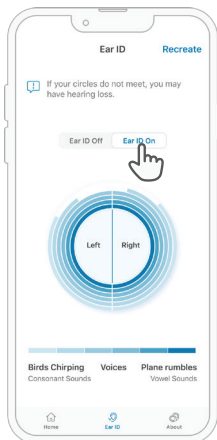

You can turn Ear ID off to turn off the custom hearing profile. The hearing aids will use the default normal hearing profile.

Note: If you repeatedly need to adjust settings to increase loudness and clarity of sound, it is recommended that you recreate your Ear ID profile to ensure it is programmed for your personal hearing requirements.

It is recommended that you recreate Ear ID every 6 months as your hearing changes over time.

Tap **Recreate** in the Ear ID screen to restart the Ear ID evaluation.

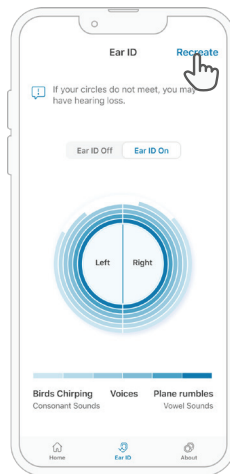

How to Turn hearing aids On/Off



Place you hearing aids back in the case to turn them off / charge.

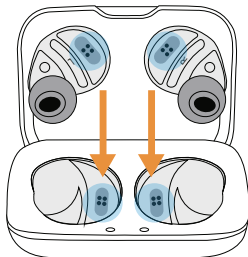

Take both hearing aids out of the case. You need to wear both at the same time.

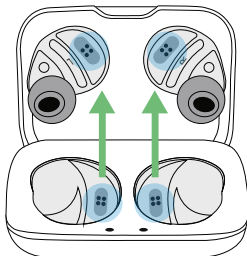

HP Hearing App

The HP Hearing App is the perfect companion for your HP Hearing PRO Hearing Aids – enabling you to personalize the way you use your hearing aids.

The HP Hearing App is the control center for your HP Hearing PRO Hearing Aids that allows you to intuitively:

- Customize the hearing aids to your hearing by creating a unique hearing profile using Ear ID.
- Use Focus to adjust the directionality of the microphones in your hearing aids to hear more clearly directly in front of you.
- Use World Volume to adjust how loud you hear your environment and the world around you.

Turn World Volume Off to reduce unwanted external sounds while you are enjoying your listening.

Turn World Volume On to hear more sound.

Easy Setup

Intuitively set up with familiarization videos to guide you through the First Time Setup process.

Personalize your hearing aids

Customize your personal listening experience using a step-by-step Ear ID process and get access to your personalized profile. Perform the Ear ID evaluation in a quiet place and pay full attention to the step-by-step guidance.

What is Ear ID

Every ear is different, and each user has unique listening preferences. With Ear ID the user has the capability to personalize their HP Hearing PRO Hearing Aids to deliver the best sound to their own hearing profile. At the core of the innovative Ear ID personalization system is the NAL-NL2* unique programming formula, used globally by hearing aid manufacturers and audiologists.

After assessing the levels of your hearing at various frequencies, the HP Hearing App automatically adjusts and creates your unique, personal Ear ID profile that is designed to compensate for your perceived mild to moderate hearing loss.

*www.nal.gov.au/nal_products/nal-nl2/

App controls

Use the Menu Bar to navigate to the Ear ID and About screen.

The Feature Buttons let you control the World Volume or the Focus features.

Use World Volume to adjust how loud you want to hear your environment and the world around you. Move the Active Dot around the dial to increase or decrease the overall World Volume.

Control your World Volume by toggling On/Off. ANC (Active Noise Cancellation) is automatically activated when World Volume is Off.

Use Focus to adjust the directionality of the microphones in your hearing aids to hear more clearly directly in front of you.

Do NOT use the hearing aids with World Volume at maximum.

Do NOT use the hearing aids with "Focus On" - when the inability to hear surrounding sounds may present a danger to yourself or others. For example while riding a bicycle or walking in or near traffic, a construction site or railroad tracks.

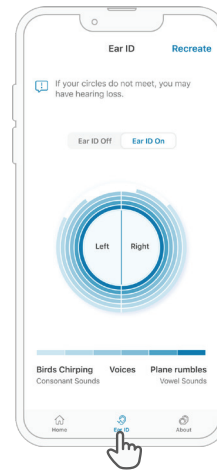
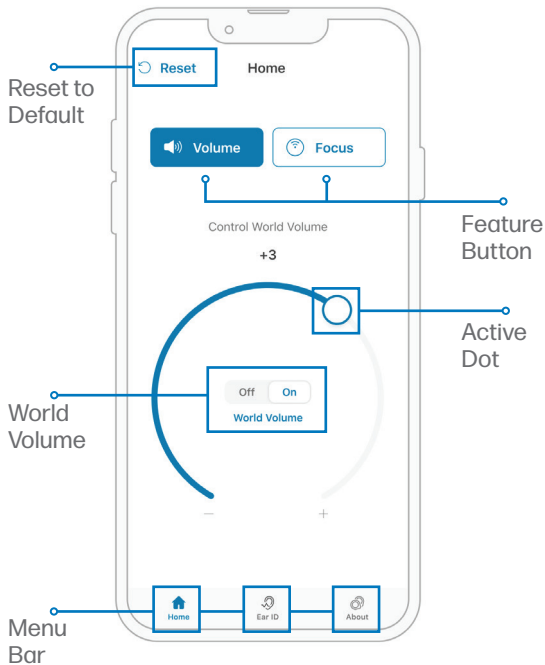

Ear ID

Ear ID measures your hearing levels and configures your hearing aids to your unique hearing profile.

Sit in a quiet place and follow the instructions. Ear ID will take about 10 minutes to complete.

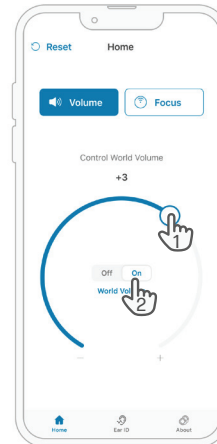

1. World Volume

Increase or decrease the level of your surroundings using the Active Dot and circular Dial.

2. World Volume On/Off

Control your World Volume by toggling On/Off. ANC (Active Noise Cancellation) is automatically activated.

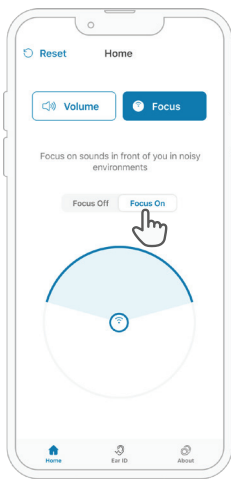

Focus On/Off

Focus on sound in front of you in noisy places to make conversations clearer.

Return to Volume Control to adjust the volume to a comfortable level.

How can World Volume help you?

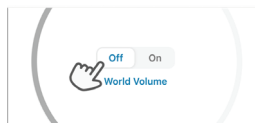

World Volume Off
(ANC Activated)

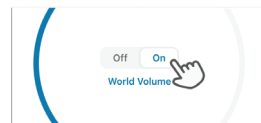

World Volume On (Allows you to adjust your volume)

You can control your World Volume by toggling the middle of the circular dial controls, World Volume On/Off. ANC (Active Noise Cancellation) is automatically activated when World Volume is Off.

Increase or decrease the level of your surroundings using the Active Dot and circular Dial.

When **World Volume** is turned **On**:

The dial on the screen controls the audio level of your surroundings. Turn it up to hear more of your external environment and turn it down to hear less.

When **World Volume** is turned **Off**:

The hearing aid microphones are not used, and you will not hear the external environment amplified.

ANC (Active Noise Cancellation) is automatically ON when World Volume is Off. This means the hearing aids will actively attempt to block noise from your external environment.

Caution

Do NOT use the hearing aids with World Volume at maximum.

Do NOT use the hearing aids with “Focus ON” when the inability to hear surrounding sounds may present a danger to yourself or others - for example while riding a bicycle or walking in or near traffic, a construction site or railroad tracks.

- Where appropriate, adjust the hearing aid World Volume to ensure you can hear surrounding sounds, including alarms and warning signals.
- Be aware of how sounds that you rely on as warnings, alarms or reminders may vary in character when using the hearing aids and World Volume.
- Be aware that it may be more difficult to identify where a sound is coming from when the Focus feature is “ON”. This is due to the directionality of the microphones picking up front facing sounds and reducing sounds from behind you.
- DO NOT use HP Hearing PRO Hearing Aids for hearing protection. They are not intended to protect your hearing in highly noisy environments.

Focus

Focus adjusts the directionality of the microphones in your hearing aids to hear more clearly directly in front of you.

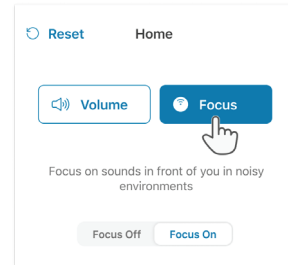

Control to activate the Focus Feature

Tap the Circle to turn Focus On/Off

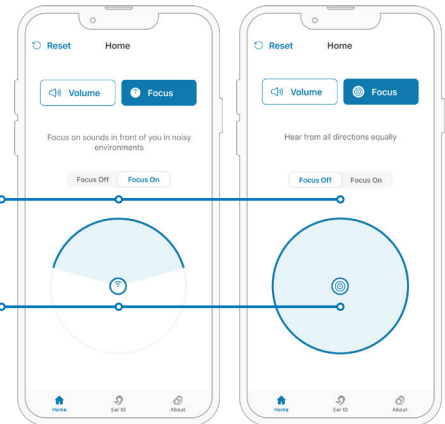

How Can Focus Help You?

Focus isolates and enhances sounds directly in front of you, which is very useful for greater clarity of conversation in noisy environments like restaurants.

You gain the most benefit from the **Focus** feature if a person is close and in front of you.

Focus can be turned on and off with the **Focus** switch, or by tapping the middle of the circle on the Focus screen.

How to Update Firmware

HP Hearing PRO Hearing Aids can be updated to the latest firmware version using the HP Hearing App. The App will guide you through the process of updating the firmware and takes approximately 10-15 minutes to complete.

Launch the HP Hearing App and select **About** if your firmware requires updating select **Update Now** and follow the prompts.

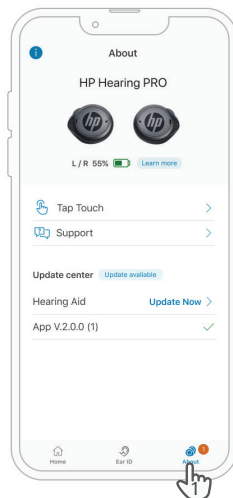

1. Red dot indicates that an update is available. Tap to select About.

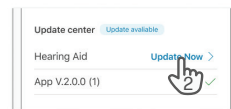

15 min

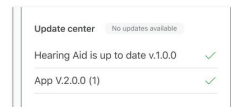

2. Tap Update Now in the Update Center to start the process. Successful update will have the green checkmark.

How to care for your hearing aids

Please follow the advice below for the best user experience and to prolong the life of the hearing aids and Charge Case. You will need a soft, lint-free cloth and a brush. (Brush supplied with the hearing aids.) After removing the hearing aids from your ears, or if they become dirty, clean them with a soft, dry, lint-free cloth.

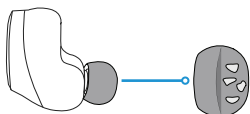

1. Inspect the Ear Tips for wax build up.

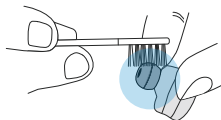

2. Gently brush the Ear Tip to remove wax, using the brush in the box.

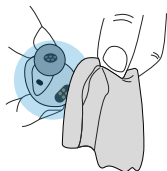

3. Wipe Ear Tips with a lint free cloth.

- Clean the Charge Case using a clean, dry cloth and the Brush provided.
- Clean the hearing aids charging bays inside the Charge Case using a lint-free cloth.
- Apply cosmetics, perfume, after-shave, hairspray, lotions, etc., before wearing the hearing aids. These products can damage or discolor the hearing aids.
- DO NOT use liquid to clean the Charge Case or the hearing aids.
- Never immerse your hearing aids in liquid.

Caution

- Keep your hearing aids away from excessive heat and direct sunlight.
- The hearing aids have IP54 limited protection against ingress of dust and water. Avoid the hearing aids getting exposed to extensive dust or water.
- Always store the hearing aids in the Charge Case to safely protect them.
- To prevent the deterioration of the battery lifetime or capacity, avoid storing the hearing aids in hot or cold environments, such as a closed car in summer, or in winter conditions.
- Never use alcohol or other cleaning solutions to clean your hearing aids or Charge Case. This can damage the hearing aids and may cause a skin reaction.
- Ear wax or other residue on the hearing aids might cause irritation. Clean the hearing aids as instructed to avoid this.

- Do not attempt to dry the hearing aids or Charge Case in an oven, microwave, or other heating equipment. This will cause them to melt and may cause burns to your skin.
- Do not store the hearing aids for extended periods of time without recharging them (max. four months).

Battery Information

Each HP Hearing PRO Hearing Aid is powered by one built-in rechargeable Li-ion coin cell battery and the Charge Case is powered by one built-in lithium polymer battery.

Battery Life

The HP Hearing PRO Hearing Aids and Charge Case batteries have an operating life of 2-3 years based on average use and charging 3 times per week.

The capacity of any type of battery will diminish after a certain amount of recharging. With lithium-ion batteries, the capacity diminishes slightly with each complete charge cycle. Lithium-ion batteries may be charged at any time and there is no requirement to fully discharge the battery before recharging it again. A single charge cycle is achieved each time you fully discharge 100% of the battery capacity and recharge the battery again. The batteries in the hearing aids are designed to retain 80% of their capacity after 400 full charge cycles giving the product a long usage lifespan. To charge, place the hearing aids in the Charge Case and close the lid. It takes up to 3 hours to fully recharge the hearing aids.

Replacement Parts and Accessories

You can purchase replacement parts and accessories from www.hphearingpro.com or contact HP Hearing PRO Support for more information.

Contact Details:

Phone: +1 (844) 540-0384

Email: support@hphearingpro.com

Help and Support

If you are experiencing a problem with the product you purchased, please email support@hphearingpro.com for support.

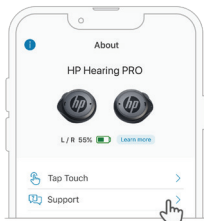

Alternatively, you can use our in-App support.

in-App Support

Access HP Hearing PRO support videos and documentation from within the HP Hearing App, Tap **About** and then tap **Support**.

Warranty

HP Hearing PRO Hearing Aids are warranted against defects in materials and workmanship for the warranty period from the date of original retail purchase (if purchased at an Authorized Retailer) or the date of purchase if purchased on the HP Hearing PRO site, www.hphearingpro.com when used in accordance with the applicable usage documentation.

The warranty period is two [2] years. For full warranty terms and conditions visit www.hphearingpro.com

FAQs and Troubleshooting

View the FAQs and full troubleshooting guide at www.hphearingpro.com

Issue: No sound	
Potential Cause	Potential Solution
Are the hearing aids turned on?	Turn the hearing aids off and then on again by placing them in the Charge Case. (See page 52)
Are the hearing aids charged?	Charge the hearing aids. (See page 41)
Is the Charge Case charged?	Charge the Charge Case. (See page 44)
Do you have excess wax in your ear canal?	Contact your physician for recommendations on how to have it removed.
Are the Ear Tips broken or clogged with earwax?	Replace the Ear Tips. (See page 32)

Issue: Hearing aids are not charging

Potential Cause	Potential Solution
Are the hearing aids sitting correctly in the Charge Case?	Reinsert the hearing aids in the Charge Case. (See page 41-42)
Is the Charge Case charged or plugged into a power source?	Are you using the USB Charging Cable provided - it is plugged into a power source. (See page 43,45)

Issue: Feedback or “whistling”

Potential Cause	Potential Solution
Are the hearing aids inserted correctly in your ears?	Reinsert the hearing aids in your ears. (See page 29-30)
Is the volume very loud?	Reduce the volume. (See page 57)
Are the Ear Tips broken or clogged with earwax?	Replace the Ear Tips. (See page 32-34)
Is your ear canal full of wax?	Contact your physician for recommendations on how to have it removed.

Regulatory and Legal Information

FCC

This equipment has been tested and found to comply with the limits for a Class B digital device, pursuant to Part 15 of the FCC Rules. These limits are designed to provide reasonable protection against harmful interference in a residential installation. This equipment generates, uses, and can radiate radio frequency energy and, if not installed and used in accordance with the instructions, may cause harmful interference to radio communications. However, there is no guarantee that interference will not occur in a particular installation. If this equipment does cause harmful interference to radio or television reception, which can be determined by turning the equipment off and on, the user is encouraged to try to correct the interference by one or more of the following measures:

- Reorient or relocate the receiving antenna.
- Increase the separation between the equipment and receiver.
- Connect the equipment into an outlet on a circuit different from that to which the receiver is connected.
- Consult the dealer or an experienced radio/TV technician for help.

This device complies with FCC and Industry exposure limits set forth for the general population. This transmitter must not be co-located or operating in conjunction with any other antenna or transmitter.

Changes or modifications not expressly approved by Nuheara could void the user's authority to operate this equipment.

Suppliers Declaration of Conformity

Trade Name: HP Hearing PRO

Model: NU320

This device complies with part 15 of the FCC Rules. Operation is subject to the following two conditions:

- (1) This device may not cause harmful interference, and
- (2) This device must accept any interference received, including interference that may cause undesired operation.

USA Address

Nuheara Limited
13555 S.E. 36th St.
Suite 100, Bellevue, Washington,
USA 98006
Toll free US number +1 (844) 540-0384

FC Left Hearing Aid FCC ID: 2AKMG-NU320L
Right Hearing Aid FCC ID: 2AKMG-NU320R

Warnings and Cautions

Important Safety Instructions

For safe and effective operation of the HP Hearing PRO Hearing Aids, please familiarize yourself with the following information.

Please follow safety instructions to avoid damage or injury and keep this information as you may need to refer to it again.



- The hearing aids should be used only as described in this user manual. Incorrect use may result in damage to the residual hearing, listening fatigue, or failure to provide sound awareness.
- Keep the device and components out of reach of children to avoid choking or swallowing.
- DO NOT use the hearing aids without the Ear Tips attached.
- DO NOT use HP Hearing PRO Hearing Aids for hearing protection. They are not intended to protect your hearing in highly noisy environments.
- Remove the hearing aids from your ears if you encounter overly loud sounds.
- Check before using the hearing aids in areas where electronics or wireless devices are restricted (such as aircraft) as they may cause interference. Refer to Electromagnetic Compatibility (EMC).
- Check with your health care professional before

using the hearing aids if you have an active implanted medical device (e.g., pacemaker). Refer to Electromagnetic Compatibility (EMC).

- DO NOT resell the hearing aids or share them with others. They are a personal device intended for use by a single user.
- DO NOT allow the hearing aids or Charge Case to become wet or submerged in liquids. DO NOT wear hearing aids in the shower or while participating in water sports. Exposure to water may damage the hearing aids and Charge Case.
- The hearing aids and Charge Case should NOT be used or charged in temperatures over 104°F (40°C) (e.g., hair dryers, hot cars, direct sunlight, candles) or placed on surfaces that exceed this temperature. Doing so could result in overheating, fire, injury, or damage to the product.
- To avoid the risk of fire or explosion, the hearing aids and Charge Case must not be charged or used in explosive or oxygen-enriched atmospheres.
- DO NOT use an unauthorized USB connection to charge your Charge Case. Connecting to an unauthorized USB connection may leave your device vulnerable.

Caution

- DO NOT use the product if any of the device components are damaged or malfunctioning. Remove hearing aids from ears and contact the HP Hearing PRO Customer Service Team by emailing support@hphearingpro.com.
- DO NOT attempt to modify any components of the device or connect any equipment or accessories not specified by the manufacturer.
- If hearing aids feel overheated, remove them from your ears. Do not place in the Charge Case until cooled to room temperature.
- Awareness of environmental sounds will be reduced when the hearing aids are placed in Active Noise Cancelling World Off Mode. Do not use this mode when full awareness of surroundings is required.
- When adjusting World Volume, turn up gradually until a comfortable level is reached.
- Avoid exposure of the hearing aids and Charge Case to sand or fine particulates as this can cause permanent damage to the device.
- Avoid dropping the hearing aids and Charge Case as this can cause permanent damage to the device.



Caution: Electromagnetic Compatibility (EMC)

Like many electronic devices, the HP Hearing PRO Hearing Aids and the Charge Case radiate and receive radio frequency (RF) energy with the potential to cause electromagnetic interference. This equipment has been tested and certified to provide reasonable protection against harmful interference in residential use (Refer to FCC Radiofrequency Compliance Information).

RF interference may still occur with the use of this product near pacemakers, defibrillators, or other medical devices; magnetic resonance imaging equipment; portable radio frequency equipment; or radio and TV broadcast antennas.

Technical Specifications

Radio Frequencies

HP Hearing PRO Hearing Aids contain the following radios. Left has Bluetooth TX/RX and NFMI TX/RX, right has NFMI TX/RX.

Radio Details			
Radio Technology	Bluetooth Classic Ver 4.2	Bluetooth LE Ver 5.0	NFMI Radio
Frequency of Operation	2402 MHz to 2480 MHz	2402 MHz to 2480 MHz	10.56 MHz
Channel Bandwidth	1 MHz	2 MHz	400 kHz
Number of Channels	79	40	1
Modulation	GFSK, π/4 DQPSK, 8DPSK	GFSK	D8PSK
Channel Technique	FHSS	FHSS	TDMA
Transmitter Power Radiated	-2.5 dBm ERP	-5 dBm ERP	9.9 dBuV/m (30 m) Field Strength
Transmitter Maximum Peak Conducted Output Power	9.0 dBm Basic Rate / 5.25 dBm EDR	4.28 dBm	NA
Receiver Sensitivity	-85 dBm	-88 dBm	NA



Recycling

This symbol means the product must not be discarded as household waste and should be delivered to an appropriate collection facility for recycling. Proper disposal and recycling help protect natural resources, human health, and the environment. For more information on disposal and recycling of this product, contact your local municipality, disposal service, or the shop where you bought this product.

Operating Conditions:

Operating temperature range: 32 °F to 104 °F
(0 °C to 40 °C)

Operating humidity: 0 - 95% RH

Atmospheric pressure range: 70 kPa to 106 kPa

Storage/Transport Conditions:

Temperature Range: -13 °F - 140 °F (-25 °C - 60 °C)

Humidity Range: 0 - 90% RH

Atmospheric pressure range: 50 kPa - 106 kPa

Time to warm from minimum storage temperature before use: 1 hour (ambient temperature 68°F or 20°C)

Time to cool from maximum storage temperature before use: 1 hour (ambient temperature 68°F or 20°C)

Dimensions:

(Single Hearing Aid): 17mm (diameter) x 24mm
(without Ear Tip attached)

(Charge Case): 76x57x29mm

Service Life



Classification: The HP Hearing PRO Hearing Aids are classified as a Type B Applied Part per IEC 60601-2-66

EXPECTED SERVICE LIFE OF PRODUCT AND COMPONENTS: 2 YEARS



This product does not contain natural rubber latex.



This product is provided non-sterile.



Do NOT use if package is damaged.

The HP Hearing PRO Self-Fitting OTC Hearing Aids complies with the following domestic and international regulations for medical devices:

IEC 60601-1:2005+A1:2012; IEC 60601-1-6:2010+AMD1:2013; IEC 60601-1-2:2014+ AMD1:2020;

IEC 60601-2-66:2019; IEC60601-1-11:2015; CTA 2051:2017; IEC 60118;

47 CFR FCC Subpart C 15.207, 15.209, 15.247. (ANSI C63.10:2013)

47 CFR FCC Subpart B 15.107, 15.109 (ANSI C63.4 :2014)

Technical Specifications

Features per ANSI/CTA-2051:2017	
Feature Category	HP Hearing PRO Over-The-Counter (OTC)Hearing Aids.
Level Dependent Gain/Compression	Utilizes 12-channel wide dynamic range compression to make conversation easier without making loud sounds too loud.
Noise Reduction	Includes Hybrid Active Noise Cancellation, which makes steady noises (such as air conditioners and car engines) less loud.
Signal-to-Noise Ratio Enhancement	Has user-selectable directional microphones (Focus) to emphasize sounds directly from in front making conversations in a noisy place easier.
Feedback Control	Reduce feedback (whistling).
Personalization	Are self-fitted by the user via the HP Hearing mobile application (App) via a smart device (phone, tablet). When utilizing the HP Hearing App and Ear ID, a separate hearing threshold assessment is not necessary to personalize amplification settings.
Coupling to the Ear	User adjustable fit for greater comfort and sound quality. The Ear Tips are a closed fit with Silicone or Memory Foam to fit snugly in the ear canal.
Wireless Connectivity	Uses Bluetooth technology to control the hearing aids via a paired smart device.

Guidance and Manufacturer's Declaration - Electromagnetic Emissions			
The HP Hearing PRO OTC Hearing Aids are intended for use in the electromagnetic environment specified below. The user of the hearing aid should assure that it is used in such an environment.			
Emissions Test	IEC60601 Test Level	Compliance Level	Electromagnetic Environment Guidance
RF Emissions CISPR 11	Group 1	Group 1	The hearing aid uses RF energy only for its internal function. Therefore, its RF emissions are very low and are not likely to cause any interference in nearby electronic equipment.
RF Emissions CISPR 11	Class B	Class B	The hearing aid is suitable for use in all establishments, including domestic establishments and those directly connected to the public low-voltage power supply network that supplies buildings used for domestic purposes.

Guidance and Manufacturer's Declaration - Electromagnetic Immunity

The HP Hearing PRO OTC Hearing Aids are intended for use in the electromagnetic environment specified below. The user of the hearing aid should assure it is used in such an environment.

Immunity Test	IEC 60601 Test	Compliance Level
Electrostatic Discharge (ESD) IEC 61000-4-2	+ 8 kV contact + 2, 4, 8, 15 kV air	+ 8 kV contact + 2, 4, 8, 15 kV air
Radiated RF EM Fields IEC 61000-4-3	10 V/m 80 MHz - 2.7 GHz 80% AM at 1 kHz	10 V/m 80 MHz - 2.7 GHz 80% AM at 1 kHz
Proximity Fields From RF Wireless Communications Equipment IEC 60601-1-2	<ul style="list-style-type: none"> · 27 V/m 385 MHz; Pulse modulation 18 Hz · 28 V/m 450 MHz; FM +/- 5 kHz déviation; 1 kHz sine · 9 V/m 710,745,780 MHz; Pulse modulation 18 Hz · 28 V/m 810,870,930 MHz Pulse modulation 18 Hz · 28 V/m 1720,1845,1970 MHz; Pulse modulation 217 Hz · 28 V/m 2450 MHz; Pulse modulation 217 Hz · 9 V/m 5240,5500,5785 MHz; Pulse modulation 217 Hz 	<ul style="list-style-type: none"> · 27 V/m 385 MHz; Pulse modulation 18 Hz · 28 V/m 450 MHz; FM +/- 5 kHz déviation; 1 kHz sine · 9 V/m 710,745,780 MHz; Pulse modulation 18 Hz · 28 V/m 810,870,930 MHz Pulse modulation 18 Hz · 28 V/m 1720,1845,1970 MHz; Pulse modulation 217 Hz · 28 V/m 2450 MHz; Pulse modulation 217 Hz · 9 V/m 5240,5500,5785 MHz; Pulse modulation 217 Hz

Acoustic Performance

According to IEC 60118-0:2015

Measurements per: ANSI S3.22:2014 (Or per ANSI CTA 2051:2017 where denoted with *)	Result
Maximum Output (OSPL90)	109.6 dB SPL, See Figure 1
High-Frequency Average (HFA) OSPL90	100.9 dB SPL
High-Frequency Average Full-On Gain (HFA-FOG)	29.4 dB SPL, See Figure 2
Reference Test Gain (RTA)	24.4 dB SPL
Frequency Response	200 to > 5000 Hz, See Figure 3
Harmonic Distortion	0.2%
Equivalent Input Noise (EIN)	28.5 dB SPL
Input Distortion	0.7%
Latency	5ms

Hearing Aid adjustment: Full-on setting
Input: 90 dB SPL

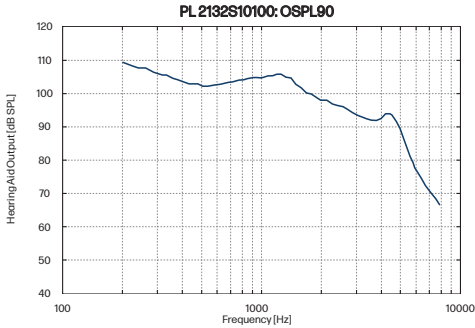

Figure 1 Maximum acoustic output: OSPL90 curve as measured in 2 cc coupler (see Section 6.2 of ANSI S3.22-2014).

Hearing Aid adjustment: Full-on setting
Input: 90 dB SPL

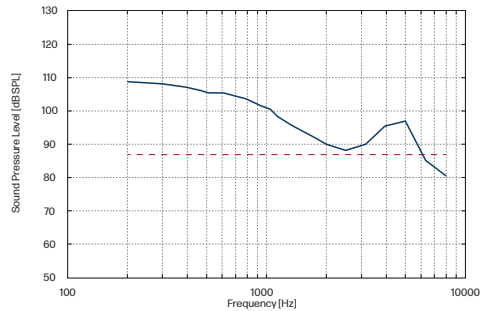

Figure 3 Frequency response measured in 2 cc coupler at 80 dB SPL: Frequency Response Bandwidth (see Section 4.1 of ANSI/CTA 2051-2017).

Hearing Aid adjustment: Full-on setting
Input: 50 dB SPL

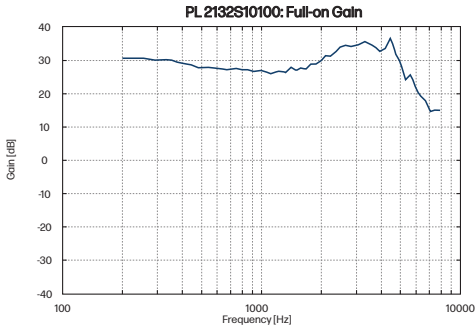





























Figure 2 Full on gain: HFA-FOG (see Section 6.5 of ANSI S3.22-2014).

Device Identification



Symbols and Descriptions:

Symbol	Description
	Review operating instructions prior to use
	Caution
	Bluetooth
	Warnings
	Product Model
	Serial Number
	Do not use if packaging is damaged
	Temperature limits of the device
	Consult Instructions for Use
	Magnetic material
	Manufacturer
	Date of manufacture
	Choking hazard
	Type B applied part
	Federal Communications Commission symbol

Symbol	Description
	Waste Electrical and Electronic Equipment Directive symbol
	Does not contain natural rubber latex
	Non-sterile
	California Energy Commission Compliance symbol
	NOTES refer to advice and tips on how to handle your hearing aid better
	Smart phone required to download app
	Adaptive technology
	Stream music
	Environmental sound customization
	Directional sound control
	Rechargeable battery
	Water resistant

Trademark Notices

Android, Google Play, Google Assistant, and the Google Play logo are trademarks of Google LLC.

Apple, iPhone, Siri, and App store are trademarks of Apple Inc., registered in the U.S. and other countries.



The Bluetooth® word mark and logos are registered trademarks owned by Bluetooth SIG, Inc. and any use of such marks by Nuheara is under license. Other trademarks and trade names are those of their respective owners.



Qualcomm aptX is a product of Qualcomm Technologies, Inc. and/or its subsidiaries. Qualcomm is a trademark of Qualcomm Incorporated, registered in the United States and other countries. aptX is a trademark of Qualcomm Technologies International, Ltd., registered in the United States and other countries.



Comply is a registered trademark of Hearing Components, Inc.

Ear ID is a trademark of Nuheara Pty Ltd registered in the US and other countries.



HP is a trademark of HP Inc. or its affiliates, used by Nuheara under license from HP Inc.



Manufacturer:
Nuheara Limited
190 Aberdeen Street
Northbridge, WA 6171, Australia

Made in Malaysia

Distributor:
Nuheara Inc
13555 S.E. 36th St.
Suite 100, Bellevue, Washington,
USA 98006
Toll free US number +1 (844) 540-0384

Support:

For assistance, if needed, in setting up, using, or maintaining the HP Hearing PRO OTC Hearing Aids, or to report unexpected operations or events, please contact:



Nuheara Inc
13555 S.E. 36th St.
Suite 100, Bellevue, Washington,
USA 98006

Toll free US number +1 (844) 540-0384
www.hphearingpro.com

© 2022 Nuheara Limited. No part of this work may be reproduced, modified, distributed, or otherwise used without prior written permission.

